

# SINGLE-LOAD FRONT-LOAD WASHERS

MHN33PRTGW/KW





## DURACORE DRIVE SYSTEM

- DuraCore Drive System is designed and tested to run 15,000 cycles\*
- Watertight, flexible triple-lip seal with garter spring keeps moisture away from the shaft, protecting the premium bearings
- Durable shaft sleeve is designed to eliminate shaft wear



## INTELLIGENT CONTROLS

- Provide flexibility to price both base cycles and cycle modifiers to help maximize earnings
- Built-in diagnostics assist with quick identification of issues
-  Easy-to-read Time Remaining Display keeps users informed
-  Intuitive cycles and options allow users to easily choose their preferred wash cycle



## ADVANCED SPIN TECHNOLOGY

- Delivers more consistent cycle times\*\*
- Offers automatic load balancing through a six-point suspension to provide optimal stability for the entire wash unit



## BUILT TO LAST

- Heavy-duty die-cast door hinge — opens 180° and is built to withstand the rigors of commercial laundry
- Durable soap dispenser — fully flushed with water during every wash cycle, helping minimize maintenance
- Porcelain enamel top — a durable finish that stands up to the demands of high traffic
-  Designed for cleanliness with soap dispenser flushed with water every cycle



CARD READER READY & NON-VEND  
MHN33PRTGW/KW (pictured)

**AMERICA**  
AN AMERICAN COMPANY FOR OVER 100 YEARS

 End user benefits

\*Based on 11-lb load, 34 min. timed cycle, Heavy Soil.  
\*\*Compared to previous model, MHN30, based on 17-lb load.

# SINGLE-LOAD FRONT-LOAD WASHERS

## MHN33PRTGW/KW



### SIDE VIEW

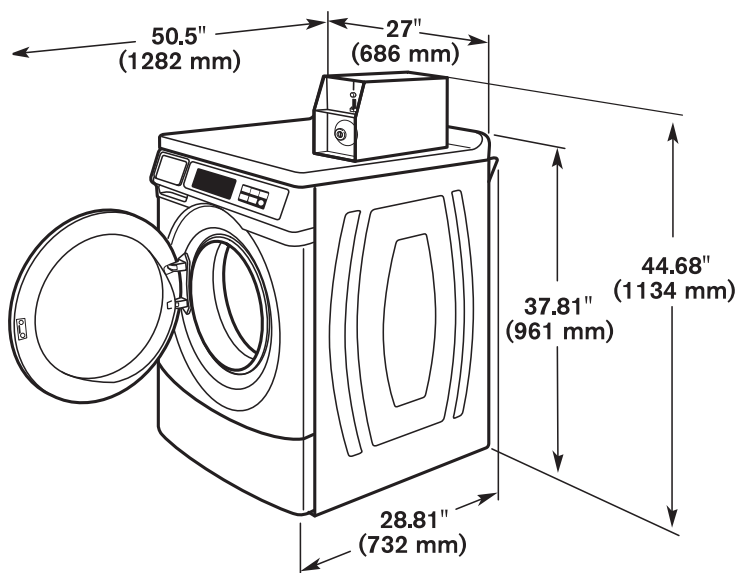

MODELS	MHN33PRTGW	MHN33PRTKW
<b>PAYMENT CONFIGURATION</b>	Card Ready & Non-Vend	
<b>CAPACITY</b>		
Cylinder Volume — cu. ft. (liters)	3.1 (88)	3.1 (88)
Cylinder Diameter — in. (mm)	21.6 (547)	21.6 (547)
Cylinder Depth — in. (mm)	13.4 (341)	13.4 (341)
IEC Capacity — lb. (kg)	23.2 (10.5)	23.2 (10.5)
<b>DIMENSIONS</b>		
Depth — in. (mm)	28.81 (732)	28.81 (732)
Width — in. (mm)	27 (686)	27 (686)
Height — in. (mm)	37.81 (961)	37.81 (961)
Door Opening — in. (mm)	14.25 (362)	14.25 (362)
<b>CRATED DIMENSIONS</b>		
Crated Width — in. (mm)	29 (737)	29 (737)
Crated Depth — in. (mm)	33.5 (851)	33.5 (851)
Crated Height — in. (mm)	40.5 (1,029)	40.5 (1,029)
<b>APPROXIMATE WEIGHT</b>		
Uncrated — lb. (kg)	235 (107)	235 (107)
Crated — lb. (kg)	244 (111)	244 (111)
<b>ELECTRICAL REQUIREMENTS</b>		
Voltage	220–240V	220–240V
Frequency	50Hz	60Hz
Breaker/Fuse — Amps	10	10
<b>WATER INLET HOSE/DRAIN HOSE</b>		
Operating Pressure — psi (Bar)	20–100 (1-8)	20–100 (1-8)
Inlet Hose Length — ft. (m)	6 (1.83)	6 (1.83)
Drain Hose Length — ft. (m)	6 (1.83)	6 (1.83)
<b>APPROXIMATE WATER USAGE</b>		
Average Total Water Usage Per Cycle — gallons (liters)	10.71 (40.50)*	10.71 (40.50)*
Average Hot Water Usage Warm Water Cycle — gallons (liters)	0.71 (2.69)	0.71 (2.69)
Average Hot Water Usage Hot Water Cycle — gallons (liters)	2.71 (10.26)	2.71 (10.26)
Extract Speed — Max G-Force/Max RPM	300/1,000	300/1,000
Motor Size — hp (kW)	0.5 (.37)	0.5 (.37)



\*Based on 2018 United States DOE J2 testing with factory preset cycles.

Dimensions are for planning purposes only. See specific instructions for proper installation. Because of continuous product improvement, Maytag reserves the right to change specifications without notice.